

APPLICABLE STANDARD					
RATING	OPERATING TEMPERATURE RANGE	-25 °C TO +85 °C	STORAGE TEMPERATURE RANGE	-10 °C TO +60 °C	
	VOLTAGE	AC 30 V , DC 42 V			
	CURRENT	2 A	APPLICABLE CABLE		
SPECIFICATIONS					
ITEM	TEST METHOD		REQUIREMENTS	QT	AT
CONSTRUCTION					
GENERAL EXAMINATION	VISUALLY AND BY MEASURING INSTRUMENT.		ACCORDING TO DRAWING.	X	X
MARKING	CONFIRMED VISUALLY.			X	X
ELECTRIC CHARACTERISTICS					
CONTACT RESISTANCE	CONTACT SHALL BE MEASURED AT DC 1 A		15 mΩ MAX.	X	-
INSULATION RESISTANCE	100 V DC.		1000 MΩ MIN.	X	-
VOLTAGE PROOF	300 V AC. FOR 1 min.		NO FLASHOVER OR BREAKDOWN.	X	-
MECHANICAL CHARACTERISTICS					
CONTACT INSERTION AND WITHDRAWAL FORCES	BY STEEL GAUGE.		INSERTION AND WITHDRAWAL FORCES : - N MIN.	-	-
CONNECTOR INSERTION AND WITHDRAWAL FORCES	MEASURED BY APPLICABLE CONNECTOR.		INSERTION AND WITHDRAWAL FORCES LOCKING DEVICE WITH UNLOCK : - N MAX. LOCKING DEVICE WITH LOCK : 50 N MAX.	X	-
MECHANICAL OPERATION	1000 TIMES INSERTIONS AND EXTRACTIONS.		CONTACT RESISTANCE: 30 mΩ MAX.	X	-
VIBRATION	FREQUENCY: 10 → 55 → 10 (Hz) (1CYC, 5min), SINGLE AMPLITUDE 0.75 mm, AT 10 CYC, FOR 3 DIRECTIONS.		① NO ELECTRICAL DISCONTINUITY OF 10 μs. ② NO DAMAGE, CRACK AND LOOSENESS, OF PARTS.	X	-
SHOCK	490 m/s <sup>2</sup> DIRECTIONS OF PULSE 11 ms AT 3 TIMES FOR 3 DIRECTIONS.		① NO ELECTRICAL DISCONTINUITY OF 10 μs. ② NO DAMAGE, CRACK AND LOOSENESS, OF PARTS.	X	-
ENVIRONMENTAL CHARACTERISTICS					
DAMP HEAT (STEADY STATE)	EXPOSED AT 40 °C, 90 TO 95 %, 96 h.		① INSULATION RESISTANCE: 10 MΩ MIN (AT HIGH HUMIDITY). ② INSULATION RESISTANCE: 100 MΩ MIN (AT DRY). ③ NO DAMAGE. CRACK AND LOOSENESS OF PARTS.	X	-
RAPID CHANGE OF TEMPERATURE	TEMPERATURE -55 → R/T <sup>(1)</sup> → +85 → R/T °C TIME 30 → 10 TO 15 → 30 → 10 TO 15 min UNDER 5 CYCLES.		① INSULATION RESISTANCE: 100 MΩ MIN. ② NO DAMAGE. CRACK AND LOOSENESS OF PARTS.	X	-
CORROSION SALT MIST	EXPOSED IN 5 % SALT WATER SPRAY FOR 48 h.		NO HEAVY CORROSION RUIN THE FUNCTION.	X	-
DRY HEAT	EXPOSED AT + 85 °C , 96 h.		NO DAMAGE, CRACK AND LOOSENESS OF PARTS.	X	-
COLD	EXPOSED AT - 55 °C , 96 h.		NO DAMAGE, CRACK AND LOOSENESS OF PARTS.	X	-
SEALING	EXPOSED AT A DEPTH OF 1 m FOR 0.5 h.		NO WATER PENETRATION INSIDE CONNECTOR.	X	-
AIRTIGHTNESS	APPLY AIR PRESSURE 17.6kPa FOR 0.5min TO INSIDE CONNECTOR.		NO AIR BUBBLES INSIDE CONNECTOR.	X	-
	COUNT	DESCRIPTION OF REVISIONS	DESIGNED	CHECKED	DATE
①					
REMARK			APPROVED	SI. MATSUZAKI	09.04.21
NOTES (1) R/T : ROOM TEMPERATURE			CHECKED	SI. MATSUZAKI	09.04.21
(2) ABOVE SPECIFICATIONS SHOWS THE VELVE IN ASSEMBLED CONDITION WITH APPLICABLE CRIMP CONTACT.			DESIGNED	TY. SUZUKI	09.04.21
(3) SEALING AND AIRTIGHTNESS SHALL BE TESTED BY APPLICABLE CONNECTOR.			DRAWN	TY. SUZUKI	09.04.21
(4) 2 A RATE CURRENT IS THE MAXIMUM CURRENT FLOW PER CONTACT. THE CURRENT CAPACITY OF WHOLE CONNECTOR IS 20.4 A MAX. Unless otherwise specified, refer to JIS C 5402.					
Note QT:Qualification Test AT:Assurance Test X:Applicable Test			DRAWING NO.		ELC4-116359-00
<b>HRS</b>	SPECIFICATION SHEET		PART NO.	HR30-8PB-12PC	
	HIROSE ELECTRIC CO., LTD.		CODE NO.	CL130-0031-4-00	△ 1/1

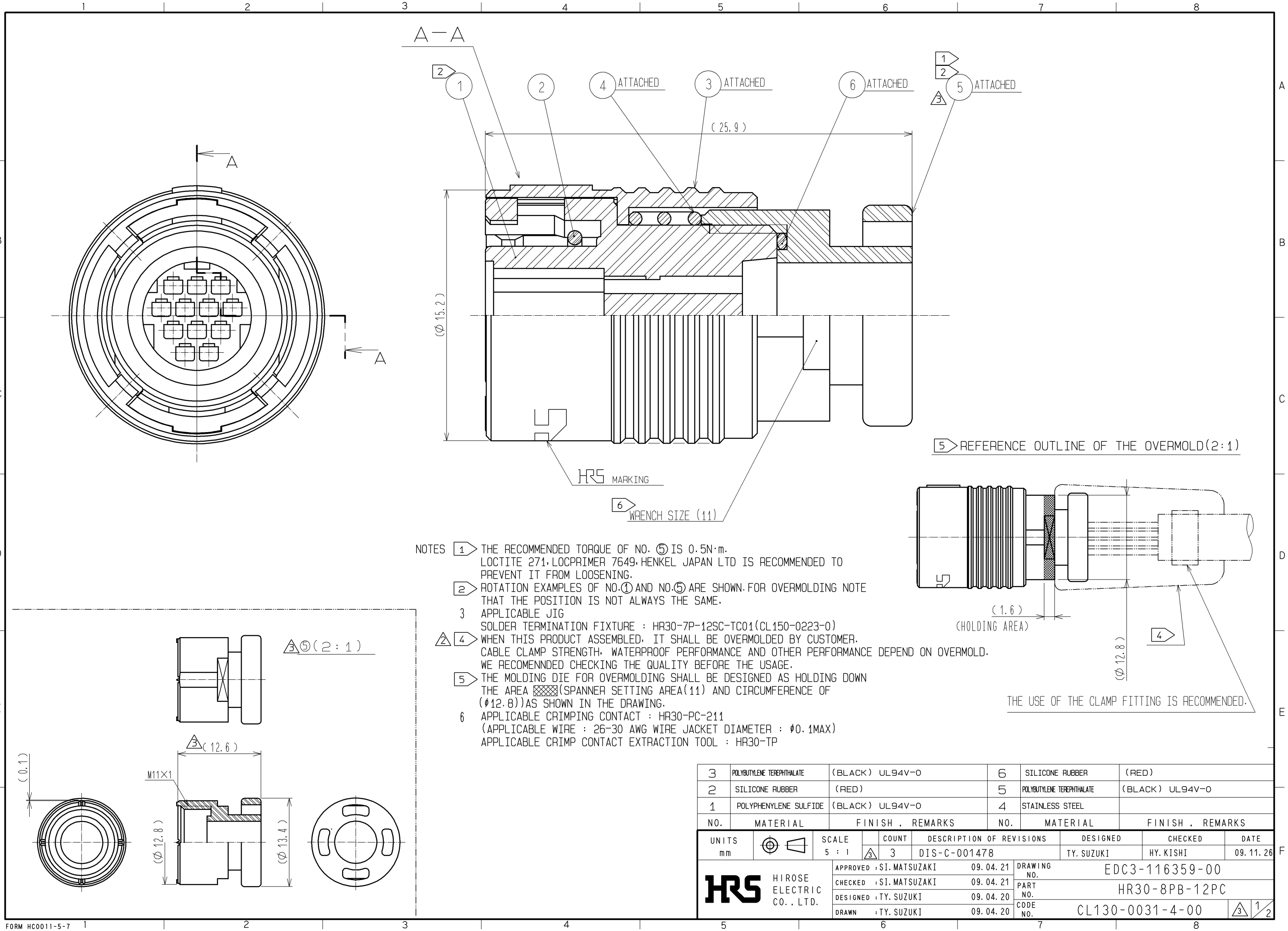

- NOTES
- ① THE RECOMMENDED TORQUE OF NO. ⑤ IS 0.5N·m. LOCTITE 271, LOCPRIMER 7649, HENKEL JAPAN LTD IS RECOMMENDED TO PREVENT IT FROM LOOSENING.
  - ② ROTATION EXAMPLES OF NO. ① AND NO. ⑤ ARE SHOWN FOR OVERMOLDING NOTE THAT THE POSITION IS NOT ALWAYS THE SAME.
  - ③ APPLICABLE JIG  
SOLDER TERMINATION FIXTURE : HR30-7P-12SC-TC01(CL150-0223-0)
  - ④ WHEN THIS PRODUCT ASSEMBLED, IT SHALL BE OVERMOLDED BY CUSTOMER. CABLE CLAMP STRENGTH, WATERPROOF PERFORMANCE AND OTHER PERFORMANCE DEPEND ON OVERMOLD. WE RECOMENNDED CHECKING THE QUALITY BEFORE THE USAGE.
  - ⑤ THE MOLDING DIE FOR OVERMOLDING SHALL BE DESIGNED AS HOLDING DOWN THE AREA (SPANNER SETTING AREA(11) AND CIRCUMFERENCE OF (φ12.8)) AS SHOWN IN THE DRAWING.
  - ⑥ APPLICABLE CRIMPING CONTACT : HR30-PC-211  
(APPLICABLE WIRE : 26-30 AWG WIRE JACKET DIAMETER : φ0.1MAX)  
APPLICABLE CRIMP CONTACT EXTRACTION TOOL : HR30-TP

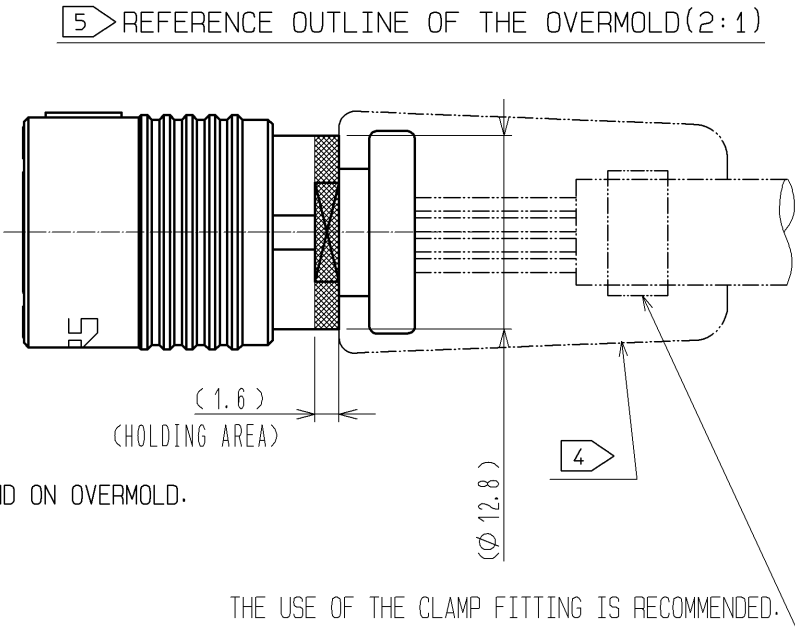

NO.	MATERIAL	FINISH . REMARKS	NO.	MATERIAL	FINISH . REMARKS
3	POLYBUTYLENE TEREPHTHALATE	(BLACK) UL94V-0	6	SILICONE RUBBER	(RED)
2	SILICONE RUBBER	(RED)	5	POLYBUTYLENE TEREPHTHALATE	(BLACK) UL94V-0
1	POLYPHENYLENE SULFIDE	(BLACK) UL94V-0	4	STAINLESS STEEL	

UNITS	SCALE	COUNT	DESCRIPTION OF REVISIONS	DESIGNED	CHECKED	DATE
mm	5 : 1	3	DIS-C-001478	TY. SUZUKI	HY. KISHI	09.11.26

APPROVED	DATE	DRAWING NO.
SI. MATSUZAKI	09.04.21	EDC3-116359-00
CHECKED	DATE	PART NO.
SI. MATSUZAKI	09.04.21	HR30-8PB-12PC
DESIGNED	DATE	CODE NO.
TY. SUZUKI	09.04.20	CL130-0031-4-00
DRAWN	DATE	
TY. SUZUKI	09.04.20	

# Assembly procedure

1. Strip the Cable Jacket.

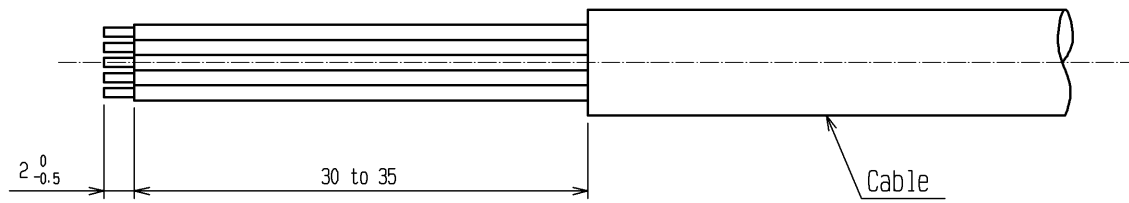

2. Insert the Spacer to the Cable.

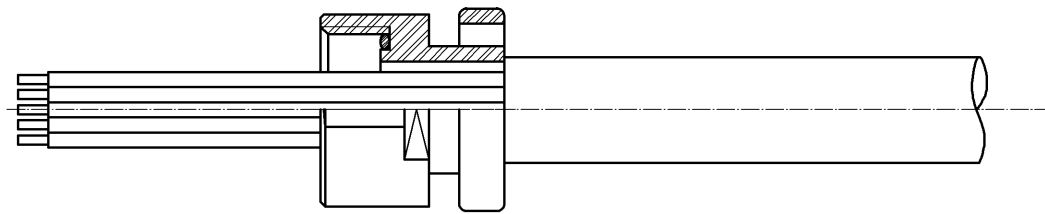

3. Insert the crimped insulated wires into the terminal.  
Note) C/H shown in table 1. ⚠

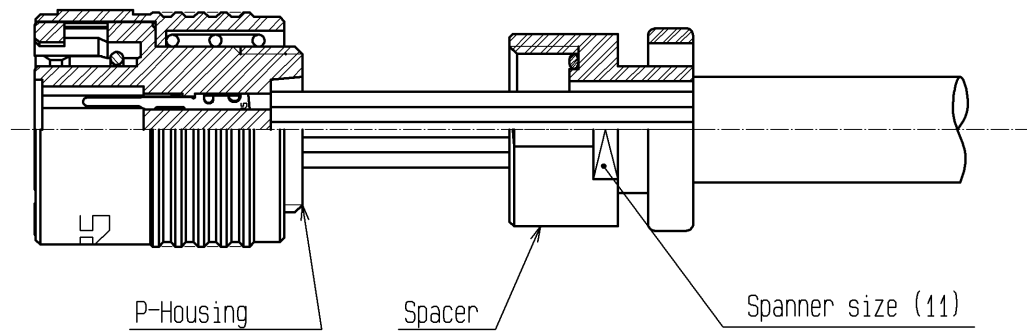
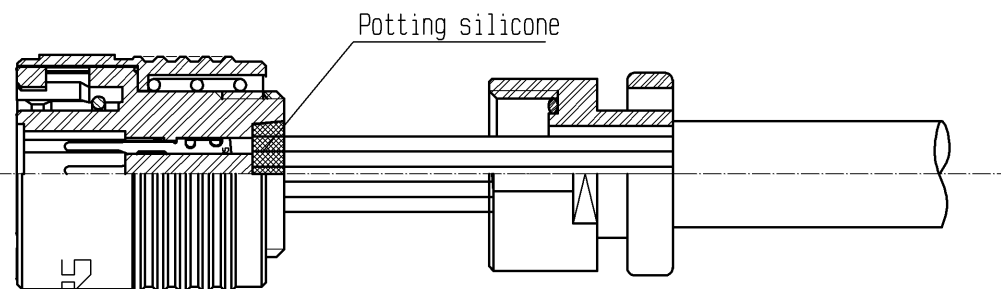

table 1 ⚠

AWG SIZE	Contact wire crimp height	Covering crimp height
UL1571 Stranded wire AWG26	0.52~0.58	0.85~1.00
UL1571 Stranded wire AWG28	0.48~0.54	0.85~1.00
UL1571 Stranded wire AWG30	0.46~0.52	0.80~0.95

4. Potting silicone into the P-Housing.



5. Assemble Spacer to the P-Housing.

(The recommended clamp torque of Spacer to be 0.5 N·m. Loctite 271, Locprimer 7649, Loctite Japan is recommended to prevent Spacer from loosening.)

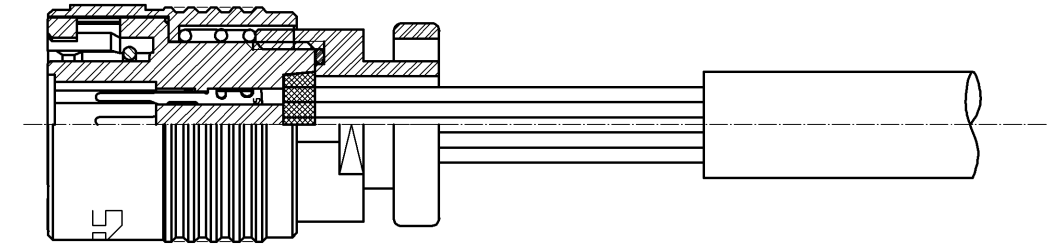

6. Overmolding.

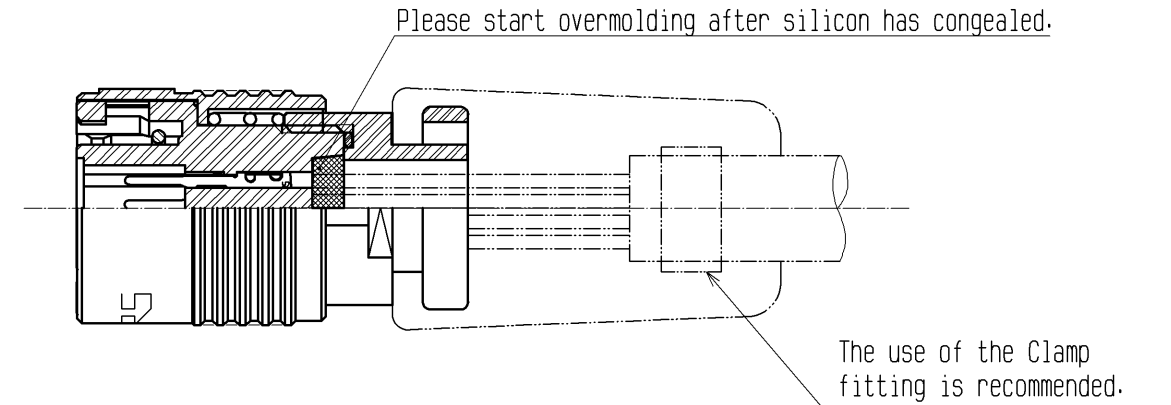

7. After Overmolding.

Please check whether silicon and overmold has exceeded to edge of contact hole which is mating point side.

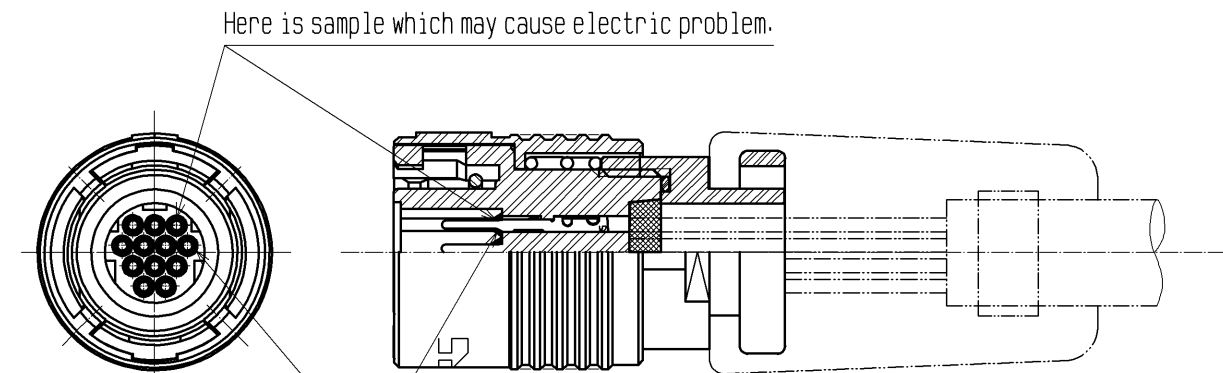

Silicone or Overmold.  
(Even if one of exceeding of overmold or silicone, it may cause electric problem.)

<b>HRS</b>	DRAWING NO.	EDC3-116359-00
	PART NO.	HR30-8PB-12PC
	CODE NO.	CL130-0031-4-00
		⚠ 2/2